

Innovative technologies

for sustainable industrial
development



johncockerill.com/industry





Metals' smart metal processing technologies are renowned for their innovative design and robustness.



Heat treatment solutions meeting the most stringent safety and quality regulations



Surface treatment lines and equipment that are fully compliant with ever more stringent environmental regulations.

A single point of contact

Innovative, fit-to-purpose equipment, lines, or complete complexes

Answering our clients' needs by providing value

Content

- Research & Development projects 6
- High value added services (audits, training, after sales services & technical assistance) 8
- Automation & Technology control systems Products & Services 10
- Metals**
- Reheating furnaces 12
- Pickling 14
- Acid regeneration 16
- Cold rolling 18
- Strip processing (mechanical, chemical, thermal) 20
- Processing lines furnaces .. 22
- Surface Treatment**
- Electrolytic and Chemical .. 24
- Heat Treatment**
- Aeronautics, Forging and other industries 26

John Cockerill not only supports its clients with its know-how and its experience, but also with product advancements and innovations, from engineering to commissioning and beyond. The final goal is clear: help clients increase plant availability and safety, while improving product quality and reducing the ecological footprint.

Toward ever greater energy efficiency

Building upon its experience, John Cockerill is constantly improving its technologies, amongst others by developing equipment dedicated to reduce energy losses in steel processes for several years now. The purpose of these solutions is to help industrialists reduce their environmental footprint, improve costs by reducing energy costs and improving their processes.

Accompanying clients in their project financing

As part of its global high value-added servicing offer, John Cockerill has supplemented its technical approach with tailored financing solutions and provides guidance and support for its customers in a global manner. Based on a long-lasting relationship with financial institutions and commercial banks, John Cockerill supports its customers in developing and implementing the most adapted financing structures.

Complete integration, from basic layout to routine operation

Whether global, turnkey solutions for complete industrial complexes, or its process sections (mechanical, chemical or thermal), specific equipment or technical solutions, John Cockerill offers the overall and made-to-measure management of its clients' needs throughout the whole of the lifecycle of their equipment: from design to commissioning of facilities, but also their conversion, expansion and upgrading. John Cockerill also provides guidance and support for its customers to improve the performance of their facilities through training, expertise services and remote assistance.

Integrated solutions, more than just the sum of parts

John Cockerill's long experience in managing international projects ensures that the equipment installed will achieve the stated performance. Knowing that a reliable industrial partner must also provide effective coordination, which is a decisive

factor in a client's success in the market, and that integrated engineering is becoming ever more important. John Cockerill provides innovative, fit-to-purpose and cost-effective engineering, coupled with high performance project management and worldwide coordination. This is the recipe for its sustainable long-term success.

Consistent product quality and increased production performance

Production flexibility often translates into complex state-of-the-art plants, yet in practice all production equipment has to be easy to operate, monitor, maintain and modernize, while producing consistent quality and providing profitable, reliable and safe operations. John Cockerill meets these requirements and provides « fit-to-purpose » engineered lines or equipment based on its long term experience and feedback from successfully running lines all over the world, as well as established low cost sourcing and in-house manufacturing.

Compliant with the most stringent safety standards

Safety is a prime consideration throughout all stages of the life cycle of our products: from design, through manufacturing, transport, installation, operation and adjustment to maintenance. Good health & safety performance is not occurring randomly but is the result of consequent and systematic action. Consequently, John Cockerill has put a dedicated QSEI management in place throughout its 15 worldwide locations.

When it comes to daily plant operations, John Cockerill believes that there are two principles underlying safe operation: machine safety and reliability. Safety is the ability of a device to keep the risk incurred by persons within acceptable limits. Reliability in operation is the ability of a system or device to function consistently for a specified duration in hostile or unexpected circumstances. An advanced level of automation optimizes processes and guarantees a high level of plant availability and reliability.

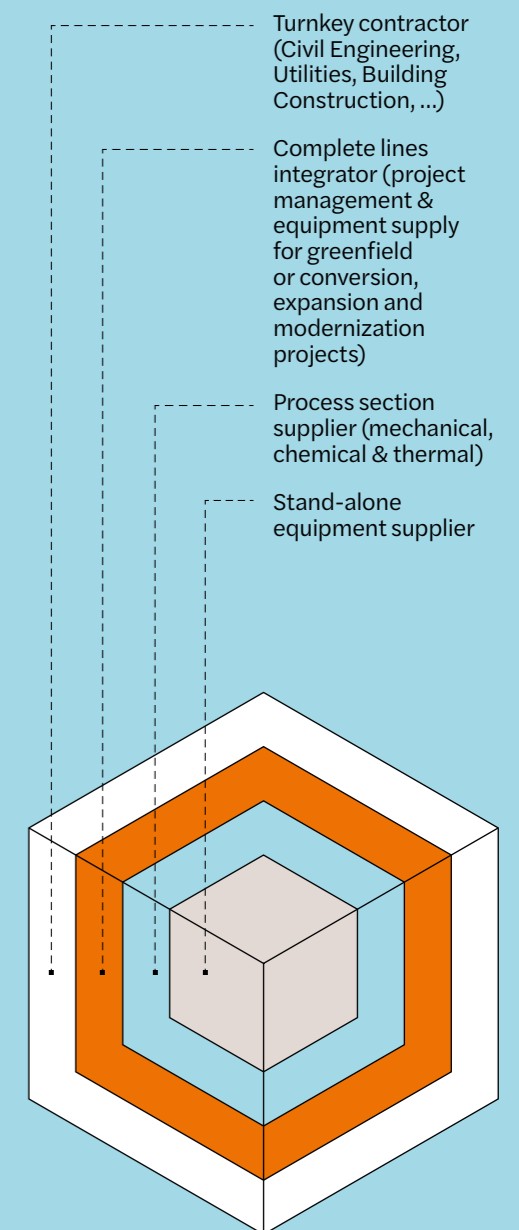

John Cockerill Industry is a globally operating engineering company

Local presence from concept to creation

John Cockerill has increased its worldwide coverage in response to the globalization of its customer base and the belief that a leading engineering company must offer an efficient global service from a local point of contact. As such John Cockerill is present in all major growth regions in the world.

Through its engineering, its assembly and manufacturing units or regional offices, John Cockerill ensures its customers low cost sourcing, but also an easy access to the entire portfolio of technologies and services, irrespective of the geographic location or the point of contact.

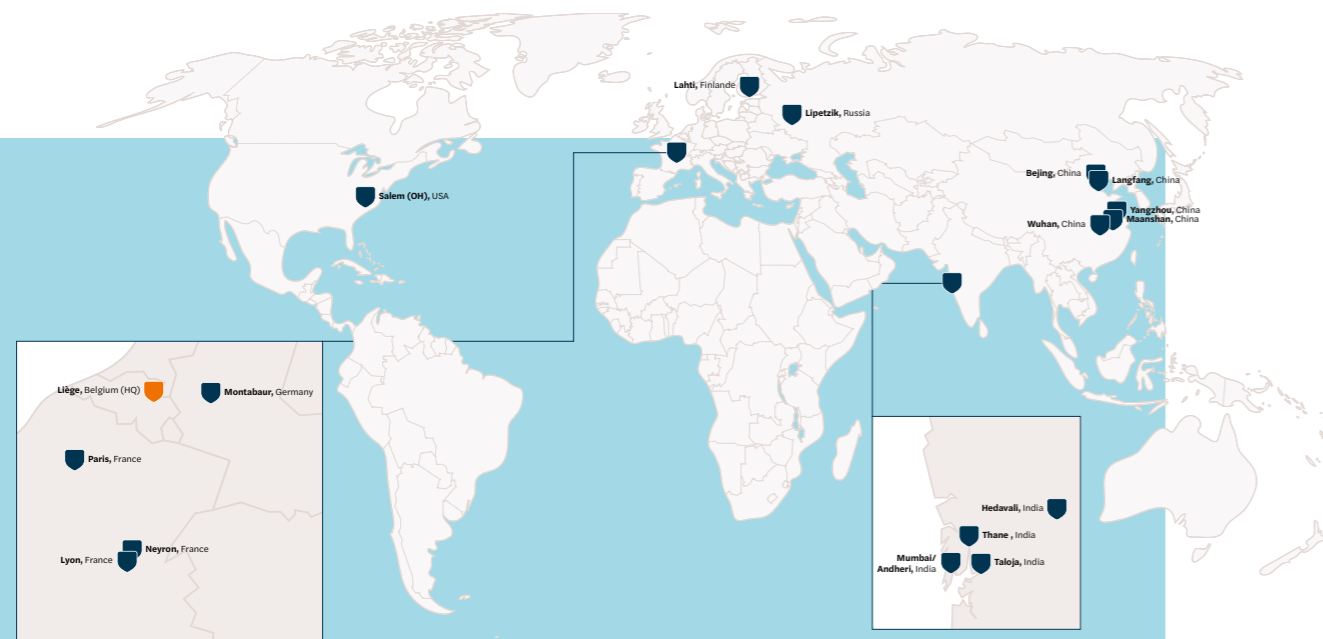

« When it comes to engineering solutions, we are renowned for our vast expertise, outstanding experience and high quality performance. What our customers appreciate just as much is the cooperative approach that shapes our business relations ».

João Felix Da Silva,
President John Cockerill Industry



John Cockerill's two workshops are equipped with state-of-the-art machining tools and ensure in-house equipment production and assembly activities that conform to the most stringent international quality and safety standards.

Taloja (India):

- Center of Excellence for Cold Rolling Mills manufacturing
- Area: 25,000m²
- Maximum handling capacity of 150 tonnes
- Versatile machine shop with heavy-duty CNC and convetional machines for high precision output
- Assembly shop with 20 assembly stations for Cold Rolling
- Mills, processing lines and furnaces
- Strong team of skilled workforce
- In-house quality inspection facility
- Integrated design facility

Hedavali (India):

- Fabrication facility produces close to 150 tonnes/month
- Modern shot blasting and painting facility
- Area: 100,000 m² with covered facility of 3000 m² with EOT cranes

Salem (USA):

- Area: 7,430 m³
- 60 t lifting capacity with 7.60 m
- Machining (CNC and Manual) / Welding / Plasma Burning / Forming / Rolling / Shearing / Saw cutting / Punching / Painting



Designing the equipment of the future

Research & development, an essential foundation for our and our client's competitiveness in a global economy



Today, in challenging times, only innovative technologies can translate the strategic needs of our clients into performance. Knowing that our growth and success are largely dependent on meeting our clients' needs & expectations, the John Cockerill Teams are focusing on developing "state-of-the art" technological innovation to help our clients to globally improve their competitiveness.

Innovation to set out for the future

Innovation and diversification are more than ever at the heart of the strategy of John Cockerill. While steelmaking remains an important market, new prospects are opening up for our Heat and Surface Treatment activities in rapidly growing markets like in the aeronautics and the automotive industry, but also in growth markets like China and in more recent years, India. Last year, the Group has further expanded its arsenal of tools to promote innovation by creating its 'Innovation Platform'. Based on the 'lean start-up' method, this platform is to accelerate and incubate the development of new internal or start-up activities.

Tomorrow, today's technology can be yesterday's

John Cockerill advises and supports ArcelorMittal, for instance, in the development of a new type of production line that is unique in the world and dedicated to the zinc coating of steel strip. This line applies the **Jet Vapour Deposition (JVD)** technique to optimize the quantities of zinc used and thus production costs. Its use on continuous annealing lines will also allow the coating of very high resistance steel grades that are difficult to galvanize by hot dipping.

A real technological breakthrough, this innovation has been installed on the Kessales site of ArcelorMittal Liège (Belgium) to meet the expectations of clients in the automotive industry and to maintain the position of steel in the race to make vehicles lighter.

SIDERWIN, is another rupture innovation project that John Cockerill is working on with 11 partners, under the helm of ArcelorMittal. This project is aiming at CO² free steelmaking combined with a significant energy reduction. The innovative electrolytic

process under development, will allow to reduce the direct energy consumption by 31% and greenhouse gas emissions (GHG) by 87%, when compared to conventional steelmaking.

The contracts of tomorrow depend on the today innovations

The combination of experience, in-depth knowledge and innovation allowed John Cockerill to book some important orders, including several Color Coating Lines (CCL), Continuous Galvanizing Lines (CGL) and Continuous Annealing Lines. All of which are featuring John Cockerill's latest process technologies. The winning comeback to the slab reheating furnace market, where John Cockerill won a major contract to replace the largest furnace in Europe for a major steelmaker is another example.

Furthermore, John Cockerill is devoting resources to developing equipment and technologies dedicated to reducing energy losses in industrial and steel processes. A number of important patent appli-

cations have been filed for these solutions, and John Cockerill recently launched several new innovative products and high-value-added services.

Spray Pickling – a breakthrough in modern pickling technology

John Cockerill's latest generation of spray pickling technology, for its part, has been designed to drastically increase pickling efficiency, hence increase process speed and reduce line length. This technology represents a breakthrough when compared with conventional turbulence pickling. The spray pickling technology substantially reduces the pickling time of steel strip by making it possible to process even difficult to pickle steel grades at a much higher speed. The new process substantially increases the flexibility in the operation of pickling lines, which allows to process a large variety of steel grades on one single line. Additionally, spray pickling requires much less process liquor and pickles at lower temperatures than conventional turbulence pickling, resulting in decreased operational and energy costs. Exploiting the full potential of the process by installing several cascades of spray modules and pickling tanks in series, potentially reduces the pickling time to less than 70%, when compared to conventional turbulence pickling. Coupled with SILASS™, John Cockerill's innovative technology for Si removal, destined to the pickling of silicon and high-strength steel grades, John Cockerill offers the ideal package solution for modern AHSS and UHSS pickling lines.

Most advanced cooling technologies to meet the requirements of tomorrow's steel qualities

To meet the growing demand for advanced automotive steel grades, which improve the safety of vehicles while reducing their weight, and in order to help its customers in the development of the latest generations of Advanced and Ultra High Strength Steel (AHSS +UHSS) grades, John Cockerill has developed several complementary high performance cooling technologies that ensure exceptional even strip cooling performance, while guaranteeing superior strip surface quality. (more detail on page 23).

Tuned to the needs of our time

Over the past decade, John Cockerill has increasingly developed proprietary E&A solutions for the group's processing lines and equipment, and has also helped to address one of the important innovation topics of our time: Industry 4.0

One of our very latest developments in this field is allowing to increase the line operators' mobility via a "Virtual Operator Pulpit". (more detail on page 11).

Environmental protection and energy savings are fully compatible with increased return on investment

Spray Pickling: Close up view of high performance spray nozzle



Europe's largest Hot Strip Mill (HSM) furnace supplied by John Cockerill



<< Technology and innovation must inspire us also in the years to come, to provide solutions to the global challenges of our time, instead of slowing down in the face of obstacles >>

Frédéric Midy, Chief Technology Officer John Cockerill Industry

Life cycle maintenance and high value added services

to best meet the strategic needs of our clients



John Cockerill not only supports its clients with its know-how and its experience, but also with product advancements and innovations, from engineering to commissioning and beyond.

Customized services and spare parts

Reduced down-time & innovative solutions to maximize productivity

Spare parts and value added parts

John Cockerill offers customized services and spare parts to minimize downtime. Thanks to John Cockerill's global manufacturing centers and our global procurement network, we can ensure the fast delivery of critical parts at competitive prices, achieving the shortest possible delivery times, especially in emergencies.

Original manufacturer components and third-party spares

John Cockerill's highly experienced GSS teams deliver either original manufacturer components or, if these are no longer available, appropriate replacement parts. If necessary, we develop a migration strategy together with the plant operator. John Cockerill also offers original part replacement of third party spares with rapid response times and fast delivery to limit downtime. Regardless of where in the world your plant is located the John Cockerill global service network has you covered.

Re-engineering of parts and components

But John Cockerill not only supplies spare parts, including third-party spares if documentation is available, its experts can also provide improvements upon request.

Based on the extensive experience of John Cockerill as a plant builder, it can re-engineer third-party spares and wearing parts to increase the performance and lifetime of these parts applying state-of-the-art technology.

Fit-to-purpose upgrading & modernization

Optimum solutions to improve plant performance & competitiveness

John Cockerill offers engineering studies, revamping, modernisation and training in order to help reduce equipment failure and operating costs and increase plant availability and safety, while improving product quality and reducing the ecological footprint of its

customers' plants. Whether the goal is the increase of capacity to satisfy the demand of downstream production or modernization to adapt existing lines and equipment to market requirements, John Cockerill has the optimum solution.

Project execution concept analysis

- Plant investigation
- Thorough analysis
- Concept development
- Minimizing downtime
- Cost effective & reliable solution

Based on many years of experience and numerous references from successful installations, our engineers have developed a systematic approach to the implementation of tailor-made solutions aiming at improving product quality, decreasing operating costs or extending the product mix. Every revamping project starts with a detailed analysis of the current situation, including an assessment of

the existing equipment and operating procedures and identification of operational bottlenecks. This analysis is the key to the future success of the project, as is the consideration of all boundary conditions and the closest possible contact with the client throughout the entire project, from planning to implementation.

Whether it is for equipment delivered by John Cockerill or any other plant supplier, our goal is to offer cost-effective solutions as a valid alternative to investment in new equipment, while minimizing downtime (e.g. pre-assembly or step by step implementation) and production start-up time, while providing top quality.

In order to boost profitability, steelmakers have to elevate their product quality and plant performance as well as expand the scope of their product portfolio. In addition to optimizing operational processes, maintenance practices must be adapted as well. John Cockerill advises clients on the latest industry standards, best practices and market trends. Expertise audits include evaluations of the technological and economic performance of selected production steps and existing maintenance procedures, followed by recommendations for improvements.

Technical assistance

Whether a client seeks improved product quality, higher production yields or greater operational flexibility, the John Cockerill experts provide technical assistance to enhance the efficiency of plant equipment. Technical assistance also covers maintenance improvements to make the best use of a plant's existing capability. But John Cockerill also provides advisory services during equipment and plant installation and start-up of new facilities.

Process & technological consultancy

Made-to-measure expertise and services for the account of industrialists

Expertise audits for capital equipment

Changing market requirements and increasing competition are forcing producers to continuously evaluate, maintain and improve their sales position.



John Cockerill's global servicing & spares offer provides comprehensive maintenance programs, including preventive and regular maintenance or small revamping jobs



John Cockerill's international training center in Maanshan, China, offers uniquely customized training programs

Automation and Technology Control

Efficient systems control for optimized production



Steel production processes are highly energy intensive and comprise many complex operations. Each of these operations has a stake in the quality of steel produced, and needs constant monitoring.

Control solutions that will enable steelmakers to execute real-time control and maintain critical process parameters

In order to help steelmakers in the energy optimization and permanent quality monitoring across the cold route of their steel production and the related production scheduling, John Cockerill has decided to further foster the development of its customized automation systems and models. With our comprehensive know-how and great experience in the steel processing industry, John Cockerill is able to offer the most adequate solutions tailored to its clients' requirements.

Process control solutions that will enable its clients to execute real-time control and maintain critical process parameters to produce higher quality products with consistent metallurgical properties.

Multi-Platform PLC (Level 1/ Level 2) and HMI system

Today John Cockerill is offering a wide variety of services as well as tried-and-tested technologies and products related to automation, as well as technology and process control. Its excellent

knowledge of industrial processes, and its experience in automation in the domains of rolling mills, processing lines, chemical technologies and industrial furnaces, are major inputs for an optimized John Cockerill design and supply of automation packages, the carrying out of studies, as well as the creation and the putting into service of software



systems for Programmable Logic Controllers (PLC), the development and upgrading of man-machine interfaces (HMI – Human-machine interface), as well as level 1 + level 2 systems.

Virtual Operator Pulpit for increased flexibility

One of our very latest developments in the field of intelligent solutions related to the topic of our time: Industry 4.0, is a "Virtual Operator Pulpit" allowing to increase the line operators' mobility via.

The first industrial implementation has been carried out on a continuous galvanizing line in Turkey. Instead of only being able to access the line data via the three fixed control rooms of the line, a tablet now allows the line operators to obtain all necessary process information, as well as to accept and implement the operators' control instructions, via a mobile HMI (Human Machine Interface).

In view of ever more complex process technologies, John Cockerill has developed a flexible and application-oriented automation and technology control. In combination with modern hardware and software systems automation, John Cockerill's has built a multi-platform system, based on its comprehensive process knowledge and return of experience from its numerous, successfully running reference lines and equipment.



John Cockerill's "Virtual Operator Pulpit" allows for easy access to the line data, and all necessary process information, as well as to accept and implement the operators' control instructions.

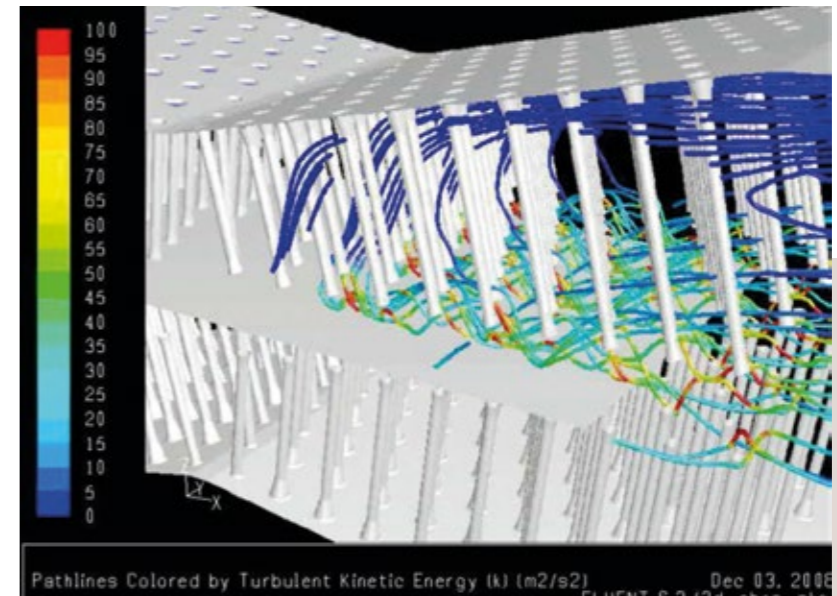

Process models and control systems:

Mathematical Models:

- Thermal Process Optimization
- Production Optimization
 - Material Tracking
 - Material Scheduling

MultiPlatform PLC (Level 1/ Level 2) and HMI Development and Upgrades:

- Automation hardware migration
- Safety upgrades
- Redundancy upgrades
- HMI upgrades
- Drive systems upgrades

Reheating furnaces

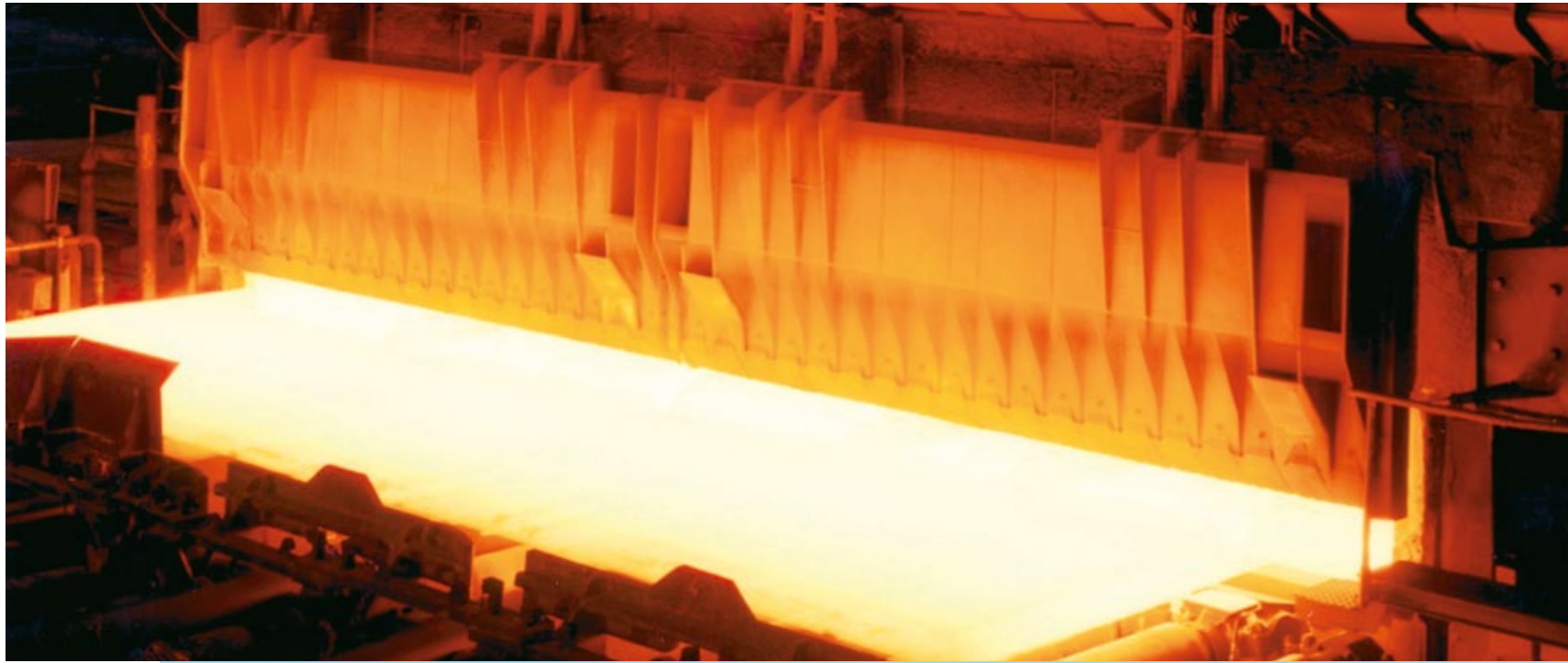

Innovative concepts for reheating furnaces to substantially improve energy efficiency and product quality

For carbon, stainless and silicon steel, John Cockerill has developed its Optimfl@me® reheating furnace. A patented furnace design that considerably improves heating quality, decreases energy consumption, reduces pollutant emissions and increases production flexibility, thanks to an optimized design and exclusive combination of:

- Customized burner sizing, configuration and management, depending on the application, including our patented double regenerative burners (DRB)
- Flat furnace shape with discharging chamber
- Unique quick restart concept based on OnOffSoft® burners firing control
- Scale Management in the furnace hearth, reducing scale formation, while increasing the time interval between stoppages for descaling
- Low NOx emissions
- R-TOP® level 2 expert software

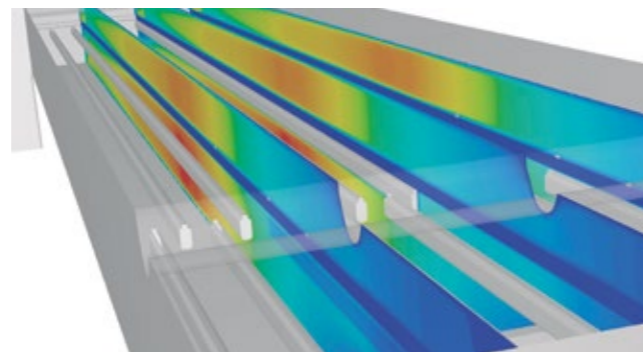

Temperature map in Optimfl@me® furnace

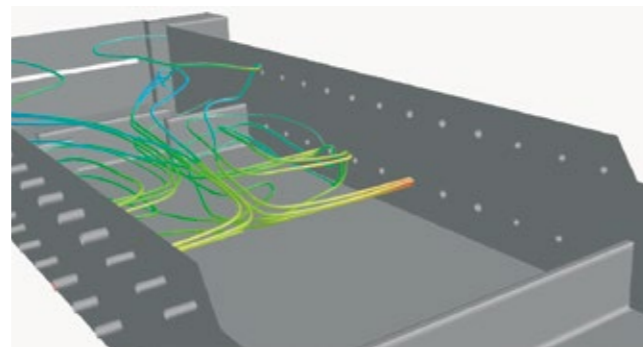

Simulation of flux gas circulation in Optimfl@me® furnace

The John Cockerill reheating furnace is designed to most effectively equalize the temperature gradient within the steel slab, bloom or billet, by optimizing the transfer of generated heat to the surface of the steel stock to be heated to a maximum. This allows for a unique temperature uniformity, while avoiding scale formation and skid marks. Besides these quality driven parameters, the latest generation of John Cockerill's reheating furnaces also addresses environmental and operational concerns and allows for lower fuel consumption by reducing heat losses from the furnace to the minimum, and increase availability and flexibility of operations.

Lower energy consumption and decreased oxidation of steel

The development of new steel grades by our clients have led to a need for increasingly sophisticated

Furnace Designs:

- **Optimfl@me® walking beam:** furnaces for slabs, blooms and billets
- **Optimfl@me® walking hearth:** furnaces for billets
- **Optimfl@me® pusher furnaces:** for slabs, blooms and billets

Process Control:

- **RTOP®:** Furnace Level 2 Control System based on physical models according to the steel grade
- **SMC®:** Skid Marks Calculation model to increase heating quality
- **Descalizer®:** Scale Reduction on heated material

Inside view of the biggest reheating furnace in Europe built by John Cockerill



Key Figures

When compared to conventional reheating furnace designs, the Optimfl@me® global concept offers the following competitive advantages:

- A yearly gain of more than 1% of furnace investment cost
- The Optimfl@me® design results in a discharging temperature decrease of about 10°C, which remarkably improves the homogeneity of the final product
- Lowest NOx emissions on the market
- Considerable scale reduction of around 10%
- Fuel consumption savings of up to 10%
- A yearly output increase of 0.2% (from 0.5 to 0.7%) with the same furnace capacity



Flameless burners

Pickling



The full range of pickling solutions for effective removal of mill scale and other surface impurities

As a market leader, John Cockerill supplies the full range of pickling solutions for both flat and long products, ensuring the effective removal of mill scale and other surface impurities from hot and cold rolled stainless steel, carbon steel or silicon steel, to non-ferrous metal strip such as aluminum, brass, etc. The resulting scale-free quality of the pickled strip improves the quality of the downstream rolling and coating processes.

Used for processing individual coils without strip joining, John Cockerill's **push pull pickling lines** are ensuring excellent operational flexibility in the face of frequently changing strip dimensions and steel grades, and also non-weldable material. Their specific design makes such lines the only practical way of descaling heavy gauge coiled product.

John Cockerill's unique v-shaped tank profile facilitates threading the strip through the pickling tank. The fact that there is no strip accumulator in the line makes this technology easy to operate and the most cost-effective method of hot band finishing. Applications range from the typical service center to the high production requirements of the largest mini mills.

Semi-Continuous- and Continuous Pickling Lines are used for high capacity production with continuous operation by stitching or welding. The strip accumulators, also called loopers, provided at the entry and exit sections of the line ensure a consistent product flow during joining, coiling and removal of the steel coils.

In continuous pickling, the line runs at constant speed, while in the Semi-Continuous Line the speed of the strip is reduced during changeover or coil joining,

due to the lower capacity of the loopers. The installation of Semi-Continuous Lines is highly cost-effective due to the simpler looper design, while Continuous Pickling Lines provide the highest production capacity.

John Cockerill's **high turbulence pickling tank technology** for continuous pickling lines is currently among the most efficient and also the most cost effective solutions on the market. In order to most effectively cover all types of applications and product mixes, these pickling tanks come in a range of profiles and acid injection systems, including the latest John Cockerill development, **spray pickling modules** (see page 11). Accurate strip and pickling process control optimizes scale removal without over-pickling. John Cockerill's Pickling Process Management (PPM) system, together with its fully automated acid control

management system, ensures the environmentally safe operation of the plant.

In stainless steel pickling applications, **John Cockerill's Neolyte Purification Systems** not only reduce harmful chromium (+6) to non-toxic chromium (+3), but also regenerate the electrolyte, thus reducing operating costs and the environmental impact of such lines, while fumes loaded with NOx produced during stainless steel pickling, are most efficiently treated in John Cockerill's latest generation of Selective Catalytic Reactors (SCR-Technology).

Fully automated Wire Coil Pickling Line with Salt Bath for Baosteel, China.



Pickling lines for long products are a highly specialized group of batch treatment lines, designed according to the product shape, process required and unique parameters defined by the client. John Cockerill's new generation plants feature automated processing using a Level II or Level III control system, multiple fill-drain cycles via an independent transportation function, cascade rinsing using spray and immersion, waste air and waste water treatment aimed at minimizing emissions, and acid control, as well as management through recovery or regeneration processes.

Along with high turbulence pickling that ensures uniform pickling conditions and high heat transfer rates, John Cockerill uses hook vibration for uniform pickling and a high pressure spray rinse arrangement that guarantees a clean surface without residual contamination.

Pickling Line Designs:

- Push Pull or Semi-Continuous Push Pull Pickling Lines
- Continuous Pickling Lines

For carbon steel, including silicon steel Continuous Pickling Lines (CPL) can be part of combined lines:

- Tandem Cold Mills (PLTCM)
- Annealing Lines for Silicon Steel

For stainless steel a CPL is incorporated into:

- Hot Strip Annealing and Pickling Lines (HAPL)
- Cold Strip Annealing and Pickling Lines (CAPL)
- Combined Hot/ Cold Strip Annealing Lines (H/CAPL)
- Direct Roll Annealing Pickling Lines (DRAP)

Batch pickling plants for ferrous and non-ferrous metals:

- Wire Coil Pickling Lines
- Tube Pickling Lines
- Bar Pickling Lines
- Plate Pickling Lines
- Universal Pickling Lines

Stainless Steel CAPL at Outokumpu, Finland



The fully automated Stainless Steel Tube Pickling Line supplied by John Cockerill to Sandviken, Sweden.



Key Benefits

- Highest product quality through uniformly pickled surface
- Highest achievable production rates
- Optimized pickling parameters through mathematical modelling
- Low operating costs with controlled utility consumption
- Environmentally friendly operation
- Low maintenance costs
- Closed loop systems for acid, water and air treatment



Replacement of chemical section for CPL at ThyssenKrupp, Germany

Acid regeneration



Europe's biggest Spray Roaster ARP - ILVA in Taranto, Italy



Fluidized Bed ARP - Riva Group in Genua, Italy

Acid Regeneration Technologies:

Carbon steel including silicon steel applications:

- Fluidised Bed Acid Regeneration Plant
- Spray roaster Acid Regeneration Plant
- CARLA® - "ready-to-install" small-scale acid regeneration system

Key benefits

- Environmental protection due to recovery of hazardous chemicals
- Virtually emission-free operation
- Recovery of costs by sale of oxide as high quality by-product
- Highest achievable production rates
- Optimised pickling due to constant operating parameters
- Independence from chemical suppliers
- Short payback time
- Present and future legal requirements on emissions are met
- Low maintenance costs
- Proven design
- Adaptable to all types of Pickling Lines

Leading-edge technology in acid regeneration for all types of acid and all available technologies

As a leader in this market segment, John Cockerill offers a modular design that guarantees its customers the optimal solution for all their individual process requirements and applications, with acid recovery rates of virtually 100%.

Eco-friendly solutions, addressing today's market requirements and increasingly stringent environmental regulations

Today two pyrohydrolysis processes are available, namely fluidised bed and spray roaster technology, both of which have distinct advantages. While both technologies are mature, it is not always easy to make the choice. A number of considerations potentially affect the decision. Being able to offer either of these processes enables John Cockerill to focus fully on its clients' specific site conditions and help them to choose the best option. Simplified processes such as our quick-change spray nozzles, the improved design of our venturi rendering it completely maintenance free, or the most modern plant control system

(PCS), are just a few examples of the features provided by the latest generation of our plants. John Cockerill's Acid Regeneration Plants (ARPs) are equipped with a highly automated control system that minimizes field intervention by the operator and enables safe and reliable daily operation from a single control room.

For the total regeneration of Hydrochloric Acid (HCl), the waste pickle liquor from the pickling line is concentrated by direct heat and mass exchange in the venturi circulation system, before being injected into the spray roaster or fluidised bed reactor, where it reacts with O₂ and H₂O to form solid iron oxide and hydrogen chloride gas.

John Cockerill's latest generation of ARPs are coming with an innovative **Combustion Air Preheating System** (patent pending) that helps to reduce fuel consumption by up to 10%.

The HCl contained in the reactor off-gas is then passed through an absorber system, using a counter-current circulation system, in which

the rinse water from the pickling line absorbs the HCl in the reactor off-gas. Thus close to 100% of the waste pickle liquor (WPL) is converted back to liquid acid, which is then reused in the pickling line. The remaining off-gas passes through several treatment steps, including the exhaust fan which regulates the negative pressure in the whole upstream system preventing gas leaks, before being released via the stack into the atmosphere.

John Cockerill's ARPs can optionally be equipped with a **Plume Reduction System** (patent pending). This newly designed, and highly innovative system not only reduces the fume at the stack, but also further reduces emission values, thus allowing to achieve the most stringent environmental regulations.

Regeneration of small-scale waste acid streams coming from galvanizing and pickling plants

While acid regeneration systems for bigger pickling installations are state of the art in the steel industry, small capacity waste acid streams are generally not regenerated due to economic reasons, thus generating a negative environmental impact.

CARLA® has been developed to address this environmentally unacceptable situation. Based on an innovative batch process to economically handle waste acid capacities down to 100l/h, CARLA® is closing the loop on acid regeneration also for installations only producing small amounts of waste acid.

The single reactor process reduces investment costs, but also the waste streams of the plant, as well as the amount of fresh acid to be purchased.

For surface treatment or waste acid treatment plants with no or limited access to conventional acid regeneration technology, the use of CARLA® will have a significant positive impact on their environmental balance.

John Cockerill's state-of-the-art acid regeneration plants, have undergone a complete value analysis and feature the full spectrum of the very latest process technologies in this field. The Twin-Stand Fluidized Bed ARP for Shandong is one of the prominent and most recent examples of this development.

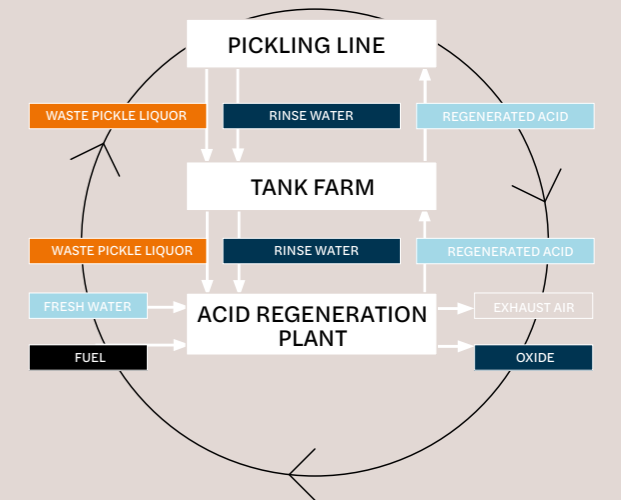

A perfectly matched John Cockerill acid regeneration plant, guarantees the efficient management of consumable process chemicals, thus minimizing the environmental impact and maximizing operating efficiency.



High-density Oxide produced by Fluidized Bed ARP

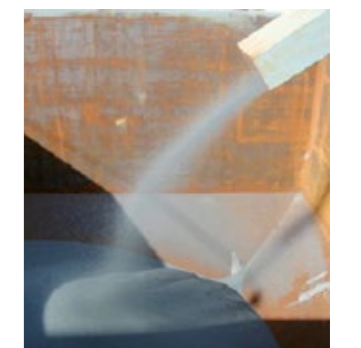

Rolling mills

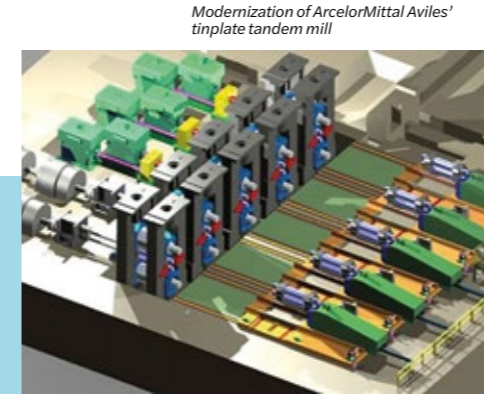

Modernization of ArcelorMittal Aviles' tinplate tandem mill



Stand-alone temper mill for automotive applications at ArcelorMittal Dofasco

Rolling Mills Technologies:

- Tandem Cold Mills (Batch or Conti-Conti)
- Pickling Lines/ Tandem Cold Mills (PLTCM)
- Reversing Cold Mills (Single or Twin Stand)
- Skin Pass Mills

Modernization and Special Equipment for Cold/Hot Strip Mills

Key benefits

- Suitable for wide range of strip width and output thicknesses
- Suitable for wide range of products (low, medium and high carbon steels, silicon steel, copper, brass and a number of alloys)
- Reliable terminal equipment reducing downtime
- Accurate tension control and steering
- Optimum strip thickness and flatness



Rolling technology combining field-proven reliability with cutting-edge innovation



Complete in-line skin pass mill and post treatment section for automotive applications at ArcelorMittal Eisenhüttenstadt

John Cockerill Industry Metals has over 30 years' experience in designing and producing steel rolling mills and equipment. Its latest generation cold rolling mills, always made to measure for individual customer requirements, offers many advantages, like reliable terminal equipment reducing downtime, accurate tension control and steering, as well as optimum strip thickness and flatness, to mention only the major ones.

A value offer that is enhanced by proven-and-tested equipment like **shear systems, tension leveling, scale breaking, mandrels and coilers**, all of which are important components in the modernization and the installation of new **Pickling Lines/ Tandem Mills (PLTCM)**.

John Cockerill has built a strong technology experts team, over the years and offers the most efficient, yet lean mechanical design and engineering for all of its mill types.

Additionally, the demand for ever higher-capacity production and improved product quality, increasingly results in existing rolling mills and equipment being in need of modernization.

As such, John Cockerill is not only supplying new mills, but is also offering customized rolling solutions aiming to cost-effectively and efficiently help customers with the modernization and the upgrading of their existing mills to meet today's need for high performance mills.

The latest development of high-end automotive and tinplate applications of its mills, as well as process models and automation packages are enriching John Cockerill's value proposition.

Rolling technology designed for all applications and requirements

John Cockerill Industry Metals designs **4-High and 6-High reversing cold rolling mills** with high output and high flexibility for all metals industry rolling requirements. These type of mills come in single or twin stand configuration.

The wide range of products able to be rolled by these mills includes low, medium and high carbon steels, along with copper, brass and a number of alloys. Additionally, a very wide range of strip widths can be treated, at mill speeds that are sufficient for the highest volume of demand within steelmaking companies. The mill model for an optimized pass schedule is provided along with the mill itself.

John Cockerill also designs and supplies **skin pass mills** with wet and dry skin pass systems. In-line skin pass mills are supplied for continuous annealing lines and continuous galvanizing lines.

Both stand-alone and in-line skin pass mills supplied by John Cockerill treat a very wide range of strip widths, with precise output thicknesses and the highest possible mill speeds, guaranteeing its customers a great level of productivity and cost-effectiveness.

Strip processing



High performance strip processing lines for every application

In the face of an ever changing business environment, and the resulting challenges for increasingly demanding quality and flexibility, John Cockerill is enabling its customers to process today's latest high strength steels (AHSS/ UHSS) including DP (dual phase), TRIP (TRansformation Induced Plasticity), FB (ferrite-bainite), CP (complex phase) and TWIP (TWIn Induced Plasticity) steels (see fig. 1).

Innovative technologies to address processing challenges related to the latest generations of high strength steels

While Advanced High Strength Steels (AHSS) and Ultra High Strength Steels (UHSS) are considered as

the dominant future lightweighting material, the steel industry is moving into the third generation of high strength steels for the automotive industry. John Cockerill is preparing for these even more challenging steel qualities, with a number of **innovative automated and modern cooling technologies** (see page 23) and its latest patented design of a pre-oxidation chamber to control the selective oxidation of the steel surface, mainly due to high Si content, during annealing prior to galvanizing, which is resulting in poor wettability and zinc (Zn) adherence.

The combined oxidation and pre-oxidation chamber incorporates a system and a method that perfectly exert the necessary oxidation control on both sides of the steel sheet.

As a global full-liner John Cockerill Industry Metals is providing unique

expertise and know-how in steel processing. John Cockerill's lines and equipment are designed and manufactured to offer maximum value, from the delivery of complete new installations, to modernization and productivity and quality improvements of existing lines.

As such John Cockerill is addressing its customers' needs for increased operational flexibility with innovative designs for **dual and combi lines**. The latest examples of this development are combi continuous annealing lines/ continuous galvanizing lines (Combi CAL-CGL) providing superior surface quality, for high-strength automotive structural components, which improves the safety of vehicles while reducing their weight, or combined continuous galvanizing lines/ color coating lines (CGL/ CCL) limiting capital and operational expenditure and

eco-friendliness as no intermediate storage, no oiling after CGL and no degreasing before the color coating is required.

But also continuous galvanizing lines (CGL) designed to apply different coatings including the very **latest AluSi coatings**.

Today John Cockerill's state-of-the-art strip processing lines, feature the full spectrum of John Cockerill's very latest process technologies: Multi-stage cleaning section, Vertical furnace (incl. John Cockerill's L-Top math model and jet cooling system with energy recovery), Zinc pot section and Air-Knife system, APC Blowstab® cooling system, In-line skin pass mill and Tension leveler, Chemical and Organic roll-coat post treatment, Side trimmer and Exit shear.

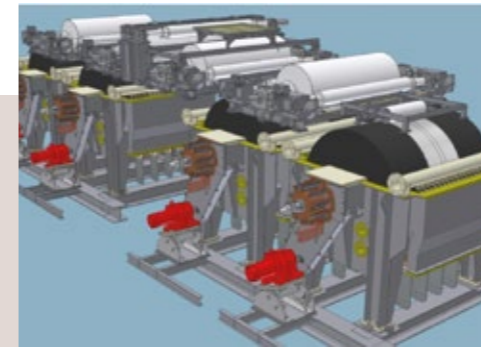

John Cockerill is providing Electro Galvanizing Lines (EGL) based on its maintenance friendly radial cell design with energy savings of up to 50% and low CAPEX due to the elimination of costly strip guidance systems and tension leveling.



John Cockerill's Chemical and Organic roll coaters come in various configurations (S, L, U, O, or C-type) and a fixed or shuttle type design, thus providing tailor-made solutions no matter what the application need. They are at the heart of John Cockerill's customized color coating lines.



John Cockerill's multi-stage cleaning process is the centerpiece of its Electrolytic Cleaning Lines (ECL) and an essential component of number of other processing lines. The modular combination of spray, mechanical, chemical and electrolytic treatment steps is providing tremendous design flexibility and is ensuring excellent cleaning efficiency of all types of steel strip surfaces.

Strip Processing Lines:

- Continuous Annealing Lines
- Continuous Hot Dip Galvanizing Lines
- Dual Product Lines
- Continuous Electro Galvanizing Lines
- Electrolytic Cleaning Lines
- Flux Type Lines
- Color Coating Lines
- Inspection/Correction/Tension Leveling Lines

Process Equipment:

- Multi-stage cleaning section
- Bath equipment (zinc pot + air knife)
- Tension levelers/ skin pass mills
- Chemical or Organic roll coaters
- Shears/ side trimmers

Key benefits

- Reliable operation
- High throughput rates
- Optimized process sections (mechanical, thermal and chemical)
- High degree of operational flexibility
- Proven high plant availability
- Consistent top product quality
- Line design adapted to lower maintenance costs (easy service of major equipment increases uptime)

TWIP (TWIn Induced Plasticity) steels (fig. 1)

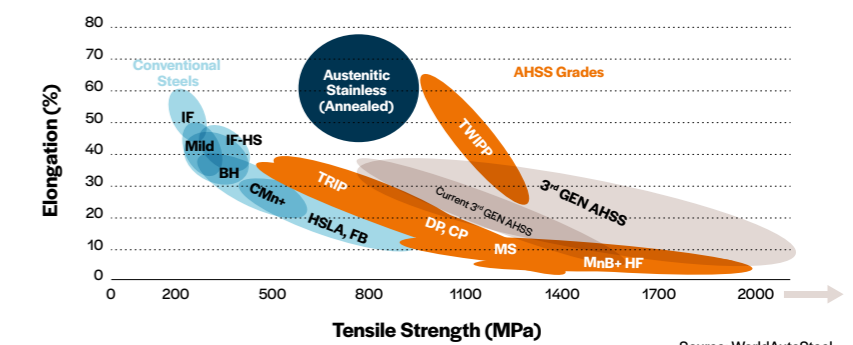

Source: WorldAutoSteel



All radiant tubes vertical furnace with convective pre-heating chamber



Double accumulator on Combi CAL-CGL, for automotive quality strip, VAMA, China



Vertical line furnace on CAL, Shagang, China

John Cockerill is providing the benchmark for many of its robust, yet innovative equipment designs for processing line

John Cockerill's zinc pot sections and air-knife systems are designed to meet the latest market requirements and have successfully been implemented in our latest reference CGLs.

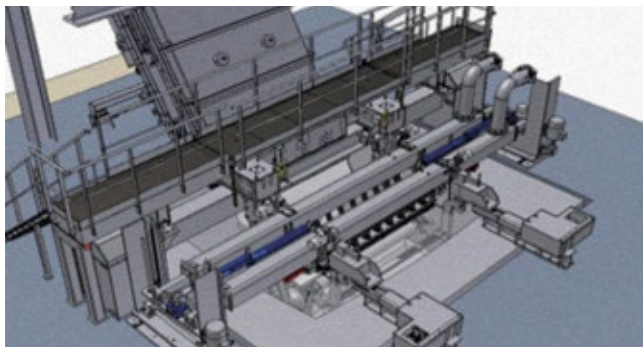

Exit shears and Side trimmers - With hundreds of successful operating references around the globe, John Cockerill is a key player for this type of equipment.



Exit Shear



Side trimmer

Innovative furnace designs to meet the most advanced requirements for production flexibility and strip quality

The latest generation of John Cockerill's processing line furnaces and corresponding mathematical models, are designed to process the widest possible range of products from fragile ultra-low carbon to high strength steels, including thin and wide steel strips, while minimizing thermal inertia to allow, next to improved energy consumption also for the quick change of production parameters, thus guaranteeing increased line flexibility.

Based on physical, mechanical and thermal models that help predict the strip behaviour on line, the optimal heating solution is developed.

The use of all ceramic fiber Non Oxidising Furnace (N.O.F.), Inconel P or PP-shaped radiant tubes, the latest generation of patented jet coolers (Blowstab®) without insulation, or the patented furnace control mathematical models L-TOP® (vertical furnaces) and LH-TOP (horizontal furnaces) controlling all process conditions whether steady or transient, are all integral parts of an optimized, state-of-the-art John Cockerill furnace design.

As such, John Cockerill set the benchmark with its patented steel strip stabilization and cooling system (Blowstab® II) guaranteeing the non-fluttering of the steel strip in the jet coolers or after the pot cooling. John Cockerill's furnace design also allows to eliminate heat and cool buckles by means of a dynamic and global control concept for strip tension, roll profiles and strip temperature.

John Cockerill's mathematical models have been successfully implemented on John Cockerill furnaces, as well as those of all major competitors to improve their productivity and the produced strip quality.

Most modern cooling technologies

John Cockerill has always been focusing on providing its customers top quality based on innovative technologies to meet the most challenging market requirements.

As such, one of the major fields of innovation of the past years has been related to the development of **several ultra-rapid cooling technologies** to meet the requirements of tomorrow's steel qualities.

To guarantee the required top strip quality and stability, as well as reduce energy consumption, John Cockerill is therefore offering three complementary cooling technologies.

The new generation of our state-of-the-art Blowstab low vibration cooling system, the Blowstab HSS™ (patent applied), offers an improved cooling performance of up to 200°C/s, as well as an ultimate strip cooling homogeneity.

Our two patented latest generations of cooling devices, IWAC®, our liquid cooling, and UDC, our Ultra Dry Cooling, allow for extremely high heating coefficients and cooling rates needed for the production of ever stronger, yet ductile, cold-rolled steel grades.

As such, IWAC® reaches cooling rates of up to 1000C/s, while the UDC attains cooling rates of up to 600C/s without strip oxidation.

The latest generation of the patented Blowstab HSS™ coolers.

Cutting-edge technology available for all line furnaces and APCs supplied by

John Cockerill, as well as for the revamping of other furnace brands.

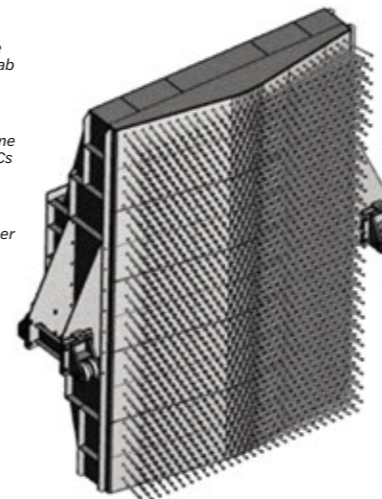

Furnace Designs for Continuous Galvanizing Lines (CGL) and Continuous Annealing Lines (CAL) (horizontal or vertical design):

- Non Oxidizing Furnaces (N.O.F.)
- Radiant Tubes Furnaces (R.T.F.)
- Any other specific chambers

Cooling systems:

- Blowstab®
- IWAC®
- Ultra Dry Cooling (UDC®)

L-TOP® & LH-top® mathematical models

Furnace Designs for Stainless Steel Lines:

- Hot rolled only (for annealing and pickling lines)
- Cold rolled only (for annealing and pickling lines)
- Combination HR and CR (for annealing and pickling lines)
- Bright annealing with high purity internals (vertical or horizontal)
- Bright annealing with muffle tubes (vertical or horizontal)

Furnace Designs for Silicon Steel Lines

Key benefits

- Dynamic and global process control
- Latest generation of burners
- Highly efficient combustion modes
- Most efficient thermal treatment of HSS
- Patented, high-performance cooling systems
- Reduction of steel alloying elements to facilitate recycling
- Optimum heating and cooling curves to achieve required strip properties at minimum energy cost



The Inconel 2P tube with its regenerative flameless and low NO_x burners for continuous annealing furnaces.

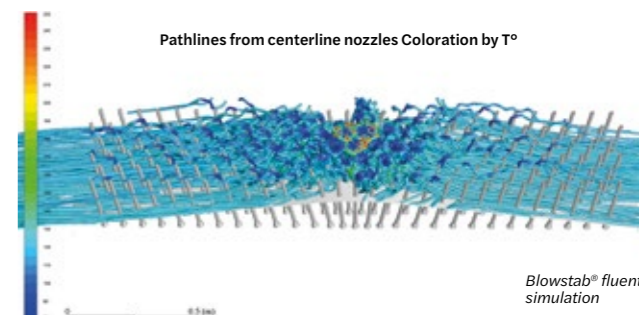

Surface Treatment



Innovative and sustainable surface treatment Customized plants and equipment for demanding industries

Based on the strong technical know-how and longstanding experience of its entities, CMI Sleti in France, Galvatek in Finland and Cockerill Tempro Surface Treatment Technologies in China, John Cockerill Industry is **one of the leading suppliers of tailor-made surface treatment lines and plants.** Additionally, we also provides **entire surface treatment workshops solutions,** including the conveying and handling of the parts to be processed. Our extensive offering not only covers the design, the project management, the sourcing and manufacturing, as well as the erection and commissioning, but also by a wide range of associated services.

A strong knowledge base

For over 40 years John Cockerill has the specific and necessary know-how to provide quality surface treatment installations designed to the specific needs of its clients. The in-depth knowledge of their clients' businesses in numerous fields of activities, such as automotive, aerospace, defense, nuclear, electronics, glass, cosmetics, decoration, building, printed circuit boards and many others, allows John Cockerill to offer surface treatment installations and equipment that are suitable for all types of applications, whether for small, medium and large parts and adapted to all types of requirements in terms of process.

Laboratory and laboratory bench for increased quality and performance

John Cockerill's in-house laboratory and laboratory

bench allow for a rigorous internal Quality Assurance and Quality Control of the produced components and the proposed surface treatment processes. The independent staff is exclusively dedicated to ensuring the accuracy of data and the implementation of quality standards throughout the production, as well as the reliable, and timely testing of components.

Energy efficiency and environmental friendliness

Looking after the environment is very important. John Cockerill Industry's Surface Treatment Division designs production units and purification processing tools that are not only optimized and coherent, but also fully compliant with current regulations.

Together with their partners within the John Cockerill Group, in charge of the specific design and manufacturing of high-quality plastic tanks, but also of the associated waste air and

liquid effluent treatment, John Cockerill Industry supplies « fit-to-purpose » engineered lines or equipment that are not only providing consistent product quality and increased production performance, but also considerably reducing the environmental footprint of these installations.

John Cockerill's worldwide surface treatment clients benefit from a complete and tailor-made offering including:

- Construction of new lines, plants and complete workshops
- Transfer, retrofit & upgrading of existing installations
- After-sales services & spares
- Training & technical support (also remote)
- Plant/ equipment qualification assistance



John Cockerill is offering its clients field-proven solutions throughout the entire life-cycle of their equipment.



John Cockerill offers not only in-house tank construction and an extensive range of ventilation solutions, but also customized robotic systems that can be single or double column, as well as without column or inclination, and come with suction hood.



John Cockerill offers new, effective, cost-saving and environmentally friendly technologies that are fully compliant with the highest standards even of industries like the aeronautics and automotive industries.

Processes:

- Chemical plating/electro-deposition
- Stripping/ Degreasing
- Pickling/ Degreasing
- Phosphating
- Die tool cleaning
- Industrial etching
- Anodizing
- Chemical milling
- Multiprocessing on Nickel, Titanium + Plastic
- Painting
- Fluorescent Penetrant Inspection

Inspection equipment:

- Automatic or manual penetrant spray booth
- Developer spray booth
- Manual/ Automatic penetrant rinsing booth
- Black or white light (UV) control room

Loading / Unloading equipment:

- SOFAT (Automatic Barrier Door Opening and Closing System)
- Storage area: Automatic or manual | Loading + unloading
- Weighing

Conveying & Handling equipment:

Specialist in the design and construction of conveying and robotic systems adapted to all installation requirements, John Cockerill proposes overhead conveyor systems, as well as contactless, side and its patented SF robots.

Waste treatment plants and equipment

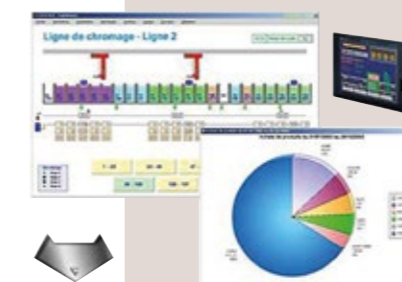

Workshop Monitoring + Supervision CATS®

- Optimized + controlled workflow management for better performance, reliability and safety.
- Cyclic or random monitoring
- Production Management
- Control-Command system
- Mono/ Multi stations

Heat treatment



Leading-edge heat treatment equipment meeting international safety and quality standards

John Cockerill Industry provides heat treatment equipment to process a wide range of materials (steel, copper, brass, stainless steel, aluminum, zirconium, tungsten, titanium, beryllium, etc.) in a multitude of sizes, shapes and thermal cycles. Backed by the combined strengths of four market leaders in heat treatment, **ATI Furnaces Europe, European Furnace Ropion (EFR), Electrical Furnace Company, also known as EFCO, as well as Stalproekt**, John Cockerill has formed a unique high performance heat treatment offer, evidenced by numerous worldwide references.

Ultimate quality and flexibility

John Cockerill's heat treatment furnaces and integrated systems set the standard for product quality and combustion efficiency, and are most effectively addressing environmental and operational concerns, allowing for lower energy consumption by reducing heat losses from the furnace to the minimum and increase availability and flexibility of operations.

Furthermore, heat treatment products supplied by John Cockerill comply with all major local, national and international safety and quality standards, including:

- AMS 2750E
- NADCAP
- NFPA 86 / 70
- CQI-9
- EN746
- UL508a

Customized high end solutions

Over the years, John Cockerill Industry has developed a wide range of high-end furnace models, designed to the individual needs of our clients. Furnace solutions are simulated numerically in order to ensure the best adapted design and to calculate the final performances of the equipment. Automation systems allow operators to easily control the system while maintaining environmental and efficiency standards. Mathematical models with specialized algorithms guarantee the precision of the heating process and thus improve furnace efficiency.

Innovation as a driver for excellence

John Cockerill has built a number of furnaces dedicated to research and testing, and is an active partner in several international research programs. Additionally, John Cockerill belongs to a worldwide

network of technical partners including professional associations, universities and technical centers. Providing the knowledge platform which is necessary to ensure continuous innovation and development for its high end heat treatment solutions.

One of the principal objectives is the analysis of the energy consumption of its different furnace designs and the implementation of the results helping to further reduce energy consumption while ensuring optimum product quality. With the final goal to continuously lower operating costs and improve customers' return on investment.

Value added life-cycle services

In addition to supplying new and upgrading of existing equipment, John Cockerill also provides technical support, services & maintenance, and spare parts, as well as fabrication and assembly out of its machine workshop in the USA.



Car Bottom Furnace with Electric Heating Elements



Rotary Hearth Furnace

Atmosphere Bell Furnace



Flexible Heat Treatment lines

Forge Box Furnace



Aluminum Homogenizing Furnaces

Roller Hearth Furnace



Equipment Designs:

Continuous, semi continuous or batch

- Box furnaces
- Tilt top furnaces
- Car bottom furnaces
- Atmosphere bell furnaces
- Movable furnaces
- Rotary hearth furnaces
- Mobile hearth furnaces
- Continuous furnaces
- Roller hearth furnaces
- Shoe pusher furnaces
- Walking beam furnaces
- Wire mesh belt furnaces
- Continuous chain belt furnaces
- Cooling chambers
- Horizontal & vertical solution / quenching furnaces
- Quenching equipment
- Standard furnaces
- Loading & handling systems
- Flexible heat treatment lines

Key Benefits

- Numerical simulation to optimize furnace designs
- Consistent and highly efficient equipment
- Dedicated operator interface and data management
- Mathematical models to improve furnace efficiency
- Optimized energy consumption
- Dedicated onsite training and support



The John Cockerill Group develops large scale technological solutions to respond to the needs of its time: preserving natural resources, contributing to greener mobility, producing sustainably, fighting against insecurity and facilitating access to renewable energy.

Its offering to enterprises, States and communities comes in the form of services and associated equipment for the energy, defense, industry, environment, transport and infrastructure sectors.

Driven since 1817 by the entrepreneurial spirit and thirst for innovation of their founder, the 6 000-strong workforce of the Group is located in 23 countries across 5 continents.

Proud of its past and aware of its own capacities to invent the processes of the future, John Cockerill intends to contribute to meeting the challenges of today's society and to generate sustainable industrial progress for the benefit of its customers, employees, the communities in which it is established, and the planet.

As an international specialist in industrial processes and technologies, John Cockerill Industry designs, supplies and modernizes reheating furnaces, cold rolling mills, processing lines, chemical and thermal treatment installations for the steel and the non-ferrous industry. It also provides state-of-the-art heat treatment technologies for the aviation, forging and casting industry, as well as surface treatment installations for all types of industries. Based on decades of experience and successfully running references all over the world, John Cockerill Industry not only supplies Green- and Brownfield installations and equipment, but also provides the related services, as well as training and technical assistance. John Cockerill's reliable and cost-effective, yet innovative solutions are always adapted to the specific needs of each and every customer.

johncockerill.com/industry

